



PAYBUY MOBILE

GSMA Presentation at Dutch Retail Organisation

Presentation Format

- 1. Going Global
 - Growth of Mobile, GSMA Overview

- 2. GSMA Approach to Mobile NFC M-Payment
 - E.g. Pay-Buy-Mobile Project

- 3. Bringing M-Payment to Market

- 4. Next Steps

1. Going Global



Worldwide Mobile Telephone Subscriber Growth

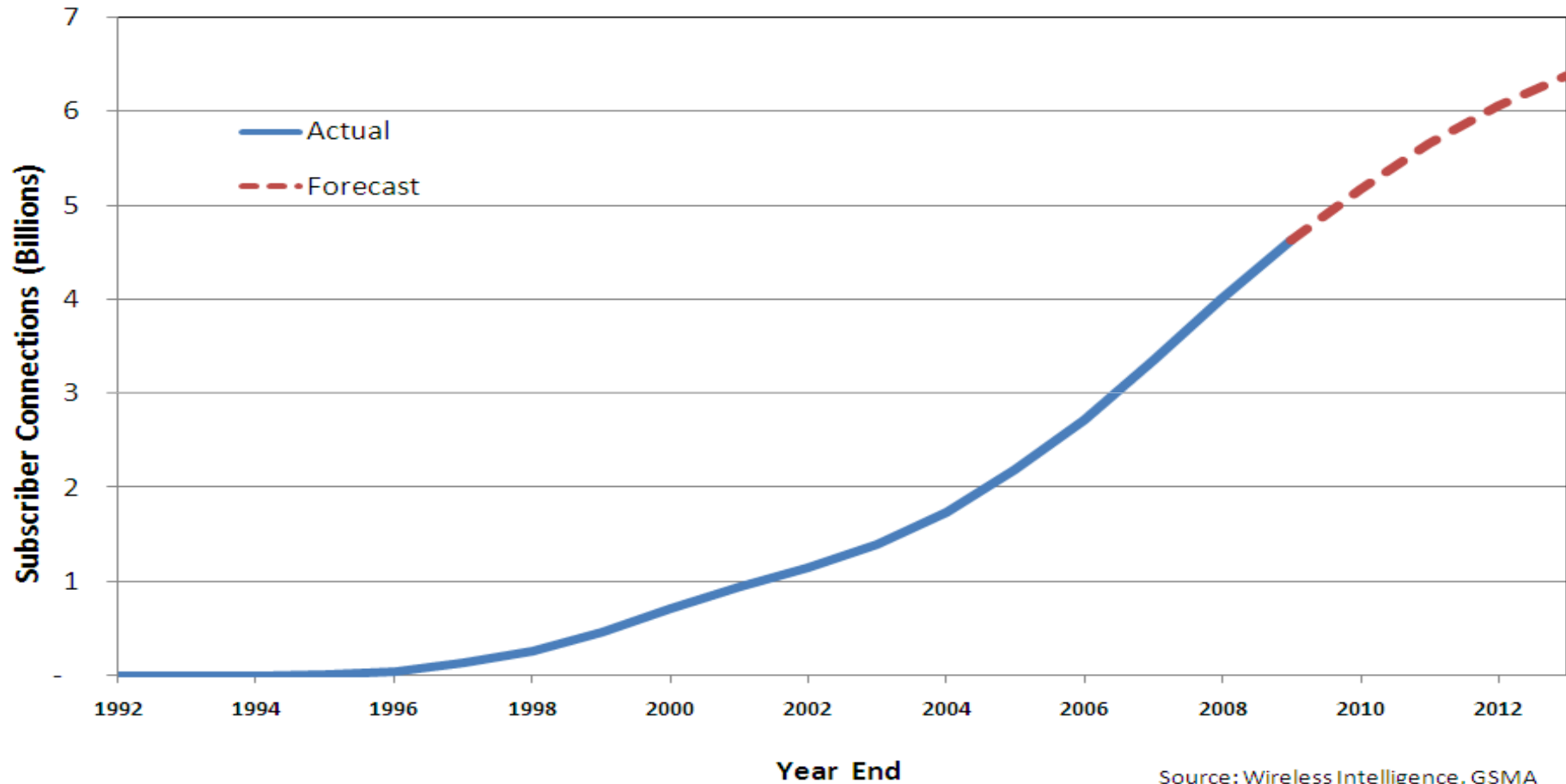

GSM World Today

Global Choice

*Over 4.1 billion
GSM/3GSM users
connected*

Global Growth

*1 million new
connections every day*

Global Data

*Nearly 7 billion text
messages are sent every
day*

Global Reach

*All 219 countries served
by GSM or 3GSM
networks*



Trends in the Mobile Phone evolution

- Processing power and sophistication of the mobile phone is growing
 - Analogue voice only
 - Digital voice and data
 - High speed data
 - Internet enabled
 - Cameras
 - Music
 - Touch screen
 - Application stores
 - Spectrum of NFC services (payments, loyalty, access, transportation etc)
 - **Mobile Wallets**
 - Location based services (personalised advertising)
 - What next ?

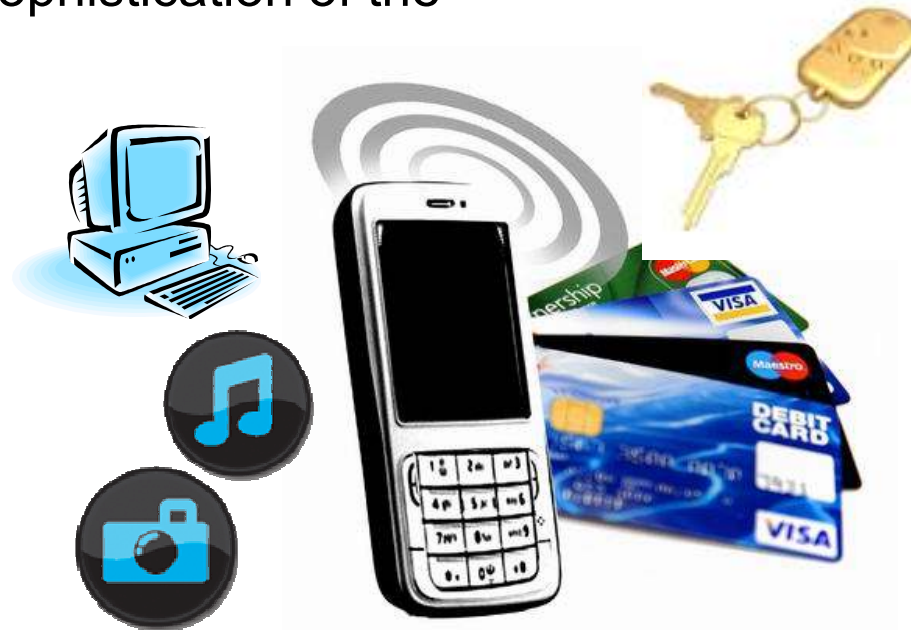

Mobile Wallet

- Will allow the customer to have easy access to a range of services
 - Proximity Payment (credit/debit cards for NFC enabled m-payment)
 - Transportation access
 - Remittance (P2P) & Remote Payment (e.g. via internet)
 - Loyalty cards, Couponing.
 - Event ticketing (e.g. concerts, theatres, sports events etc)
 - Other customer selected applications



Opportunities in Mobile-Commerce

- Expect over 600 million Mobile wallets by 2011
- Expect 1400 million Mobile wallets by 2015
- Expect over 1.7 Billion unbanked people with mobile phone by 2012
- Total Mobile Payment Market 250 bln. By 2012
- 50% proximity

Source: Wireless Intelligence, GSMA

Source: Wireless Intelligence, GSMA

Source:
GSMA

Source: Artur Little/AIB/Juniper

The GSMA

- Represents the interests of the Mobile Communications Industry Worldwide
 - Over 750 Operators Members across 219 countries/territories
 - Over 200 Associate Members (Manufacturers & Suppliers)
 - Founded 1987
 - See www.gsmworld.com
- GSMA is helping to create new business opportunities for its members
- GSMA is working to ensure that mobile and wireless services work globally
- **Core belief : Global Interoperability**
- **Strong anti-trust compliance policy**



Key GSMA themes in 2009

- **Mobile Money**
- Mobile Broadband
- Mobile Internet
- Industry Stewardship
- Environment

Mobile Money

- The MM theme comprises a number of key GSMA projects/initiatives

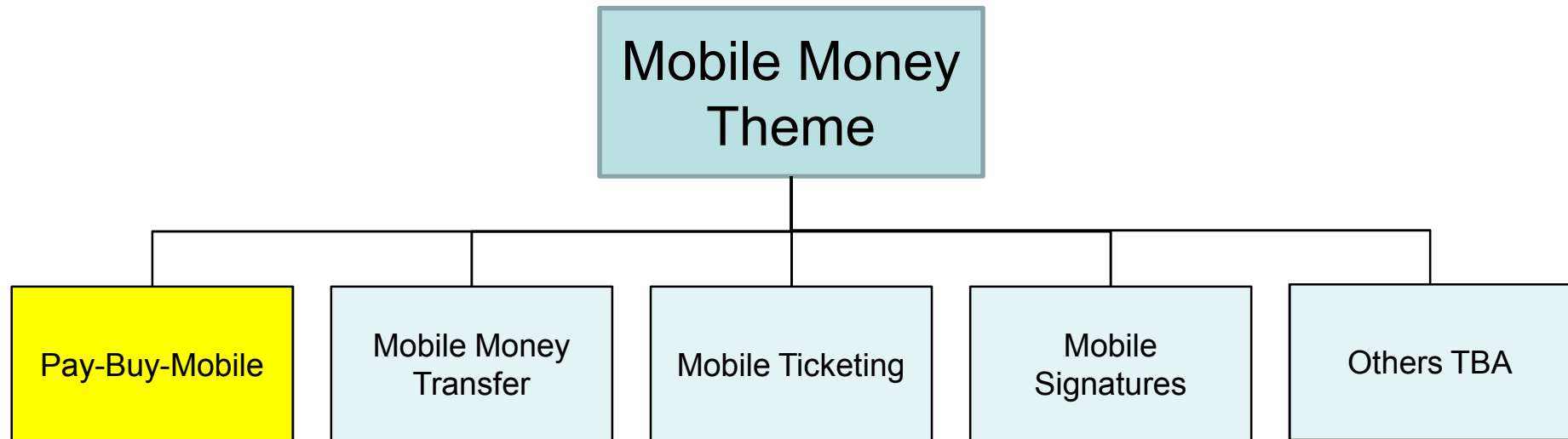

- Objective is to develop a common and coherent approach across the related Mobile Money projects and initiatives

2. GSMA Approach to Mobile NFC M-Payment



The Technology



+



+



=



Mobile Handset

NFC Technology

UICC Secure Element

Pay-Buy-Mobile

The focus of the GSMA project is to combine the capabilities of the NFC technology and the UICC, as a SE, into a simple and efficient user experience.



Pay-Buy-Mobile: Concept

- **Common global approach** : use of SIM (UICC) based credit/debit card applications and Contactless/ NFC contactless technology
- **Avoid fragmentation**, ensure global interoperability between handsets, chip cards and point of sale terminals, regardless of manufacturer
- Embedding mobile contactless payments e.g. credit/ debit transactions in the UICC/SIM card will **extend the role of mobile** phones in users' everyday lives.
- Effectively, **putting your credit/debit cards in your phone** for simple and easy payment



Provision Credit
Card Application
into the UICC/SIM



Tap and Pay



Goods
Purchased

The UICC is the most appropriate NFC secure element for the mobile phone

- Portable and transferable (across devices and networks)
- Universal (global penetration)
- Dynamic remote management (a proven and widely deployed platform)
- Logical security and physical security
- Long life cycle, typically longer than for devices
- Standardised
- Host secure application (each service provider has an exclusive control over his own application)
- SCOPE of the GSMA NFC and Pay-Buy-Mobile Projects was a SINGLE Secure Element – the UICC

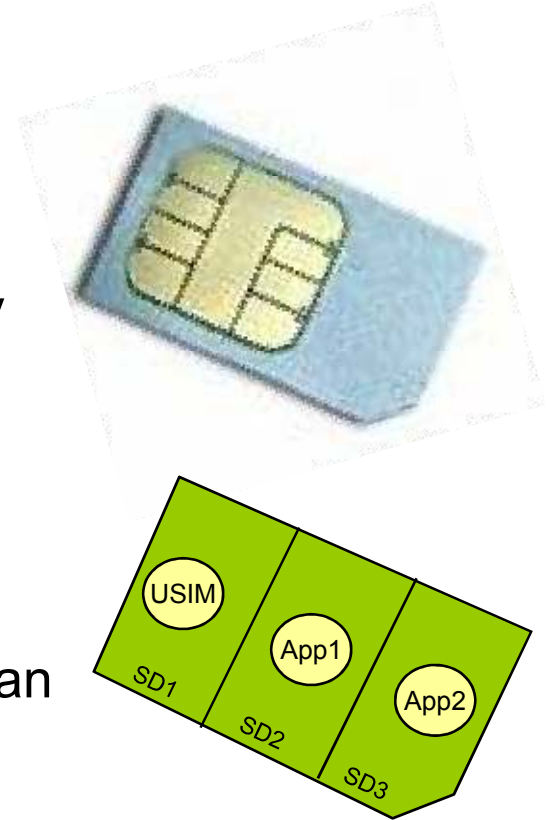

Pay-Buy-Mobile: Provisioning and Usage

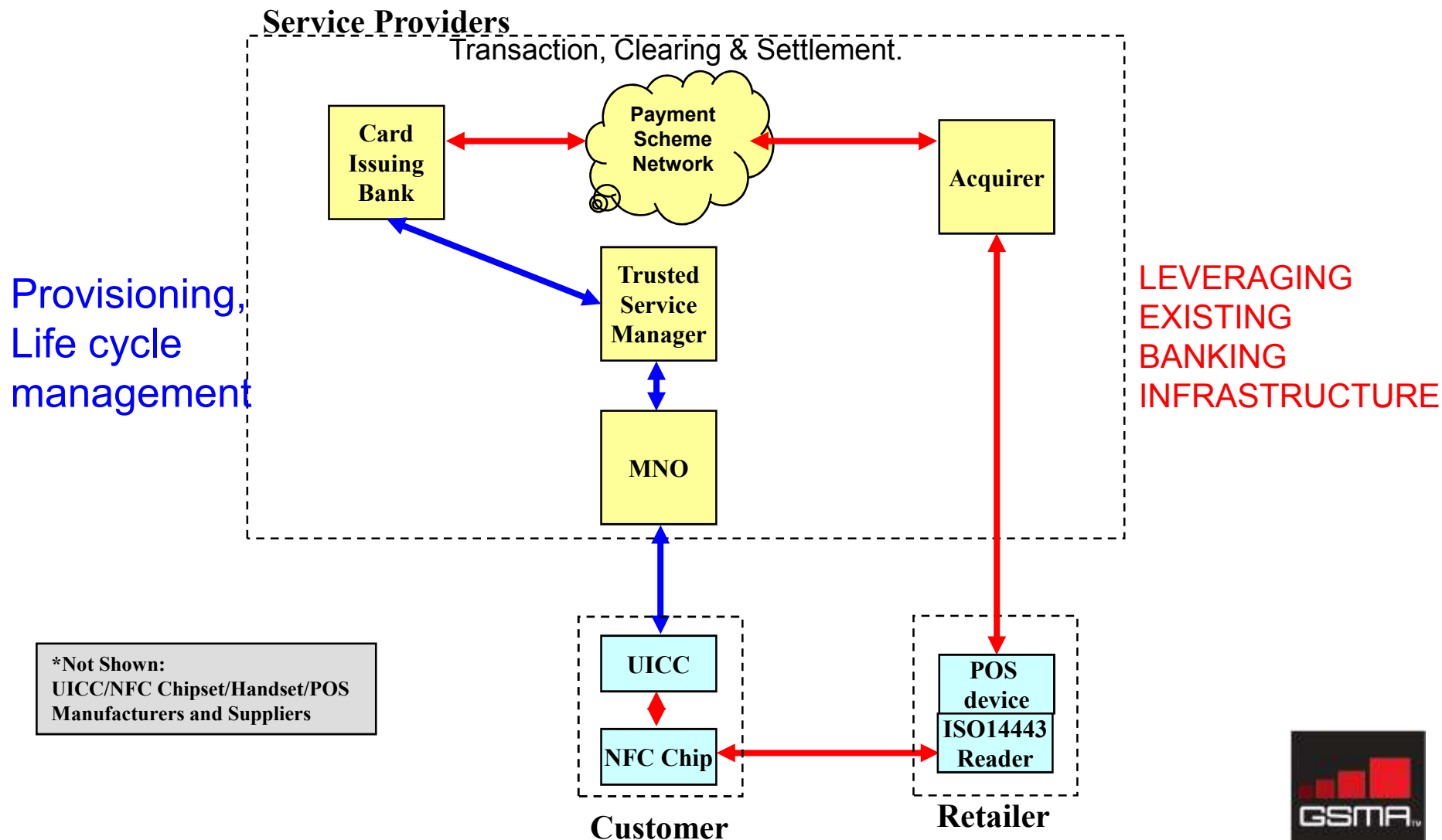

A complex NFC ecosystem: so collaboration is **key**

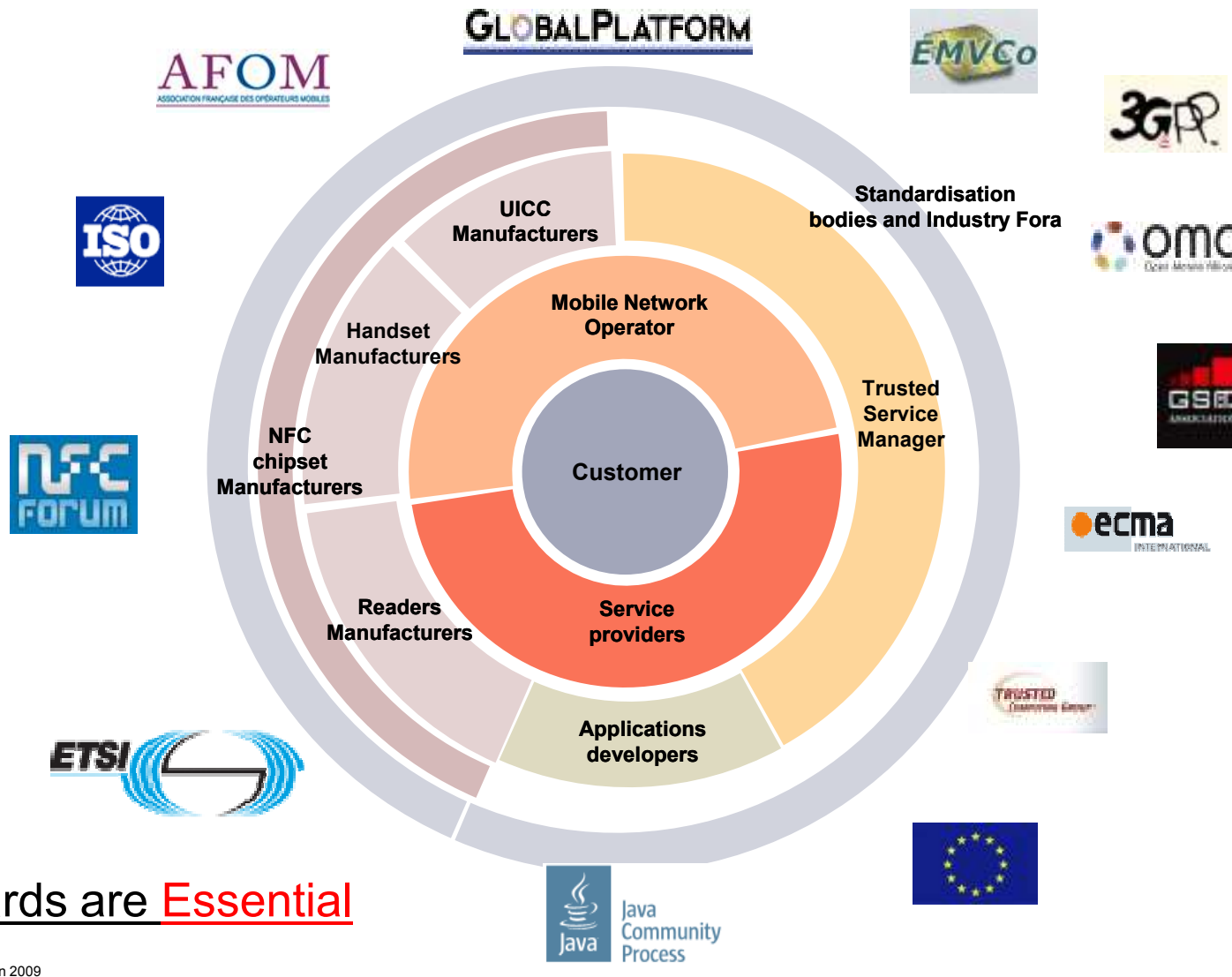

Standards are **Essential**

Collaborative activities

- ETSI-SCP: Established
- EMVCo: Established 5th September 2008
- EPC: Established 30th June 2008
 - see: http://www.gsmworld.com/news/press_2008/press08_45.shtml
- MasterCard and Visa: Established. Both are in close collaboration with MNOs in a number of pilots around the world
- Retailers: In progress (where can we help each other?)
- Others:
 - Frequent dialogues with key industry players
 - Handset, Chipset, UICC manufacturers, Industry Forums

Whose Customer?

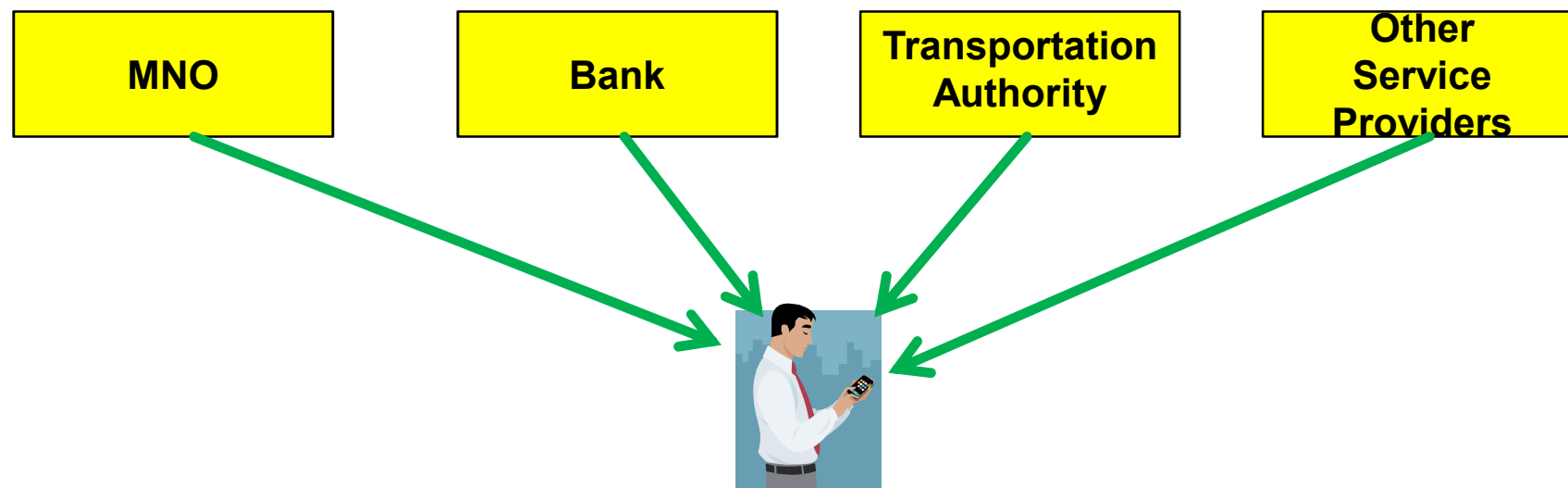

- MNO for Telephony Services
- Banks for Banking Services
- Transportation Authority for Transportation Services etc.
- Other Service Providers for other Services

Value For All In A Stable Mobile NFC Ecosystem

A new role: Trusted Service Manager

- To distribute and manage NFC services to the MNO customer base
- To act across Services Providers (banks, credit card...) and MNOs
- This role can be performed by independent third parties, MNOs or Service Providers

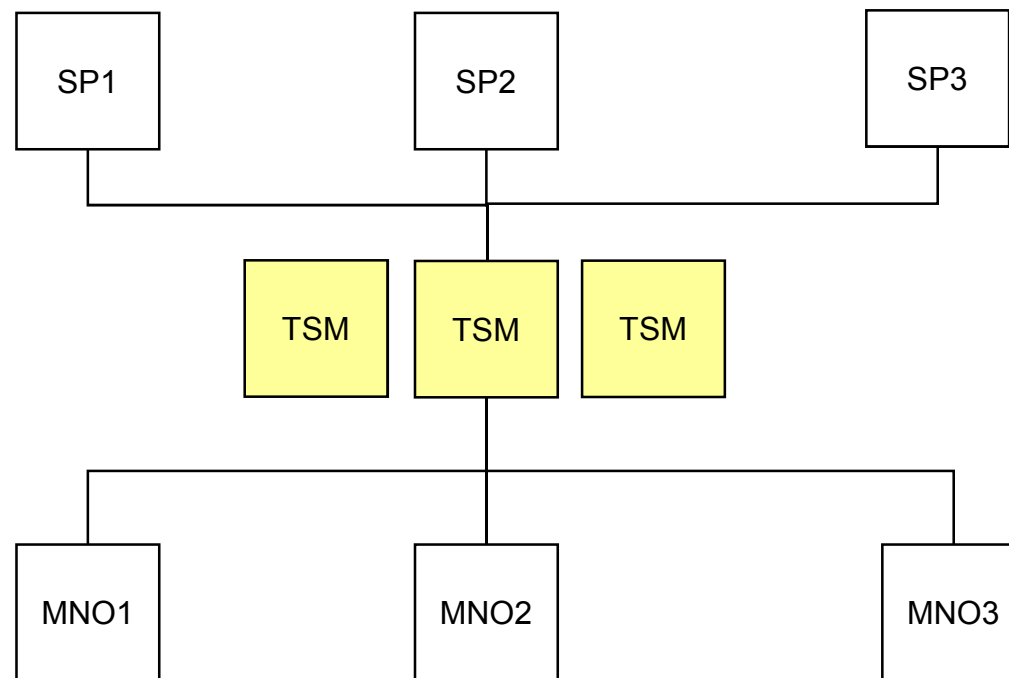

2. Example Pay-Buy-Mobile Project



PAYBUYMOBILE

52 Participating/supporting MNOs

1. AT&T (Phase 2 co-lead, Phase 3 Lead)
2. KTF (Phase 1 Lead, Phase 2 co-lead)
3. Astelit
4. Brazil Telecom
5. Celcom
6. Chunghwa Telecom
7. CMCC
8. Dialog
9. Econet
10. EITC
11. Etisalat
12. FarEasTone
13. GlobeTel
14. IMC Island
15. Kall
16. KPN
17. Maxis
18. MCI
19. Meteor
20. MobiCom
21. Mobilkom Austria
22. Mobitel d.d.
23. MTN
24. MTS
25. NTT DoCoMo
26. Orange
27. Partner
28. Pelephone
29. Rogers
30. SFR
31. SINGTEL
32. SINGTEL OPTUS
33. SK Telecom
34. SMART
35. Softbank Mobile
36. Starhub
37. Swisscom
38. Taiwan Mobile
39. TDC
40. Telefonica-O2
41. Telenor
42. TeliaSonera
43. Telecom Italia
44. Telstra
45. Telus
46. Turkcell
47. T-Mobile
48. Vimpelcom
49. Vodafone
50. Wataniya
51. Wind
52. Zain

© GSM Association 2009



Pay-Buy-Mobile initiative: Pilot status

- Pilots underway in 11 out of 14 planned countries

1. **Australia**
2. **Canada**
3. **France**
4. **Ireland**
5. **Japan**
6. **Korea**
7. **Malaysia**
8. **Norway**
9. **Philippines**
10. **Singapore**
11. **Switzerland**
12. **Taiwan**
13. **Turkey**
14. **USA**

Legend

- Pilot underway
- Pilot to be launched



3. Bringing Mobile NFC to Market



Mobile NFC: Huge potential and Strong Demand

- Mobile NFC offers the prospect of bringing a wide range of services that will bring ease and convenience for the end-user
- Results from trials and Market Research show that there is **STRONG** Customer Demand for Mobile NFC
- Huge level of cross-industry involvement in NFC
 - Some governments are getting involved
- Many Operators keen to perform commercial launch
 - All the major handset manufacturers are providing handsets for trials

Mobile NFC: What's in it for a Retail organisation

- Interactive marketing channel that can be used for varies of purposes.
 - Loyalty schemes can be integrated on the same NFC Mobile and SE
 - Also available are Couponing, Ticketing, Scanning, Advertising and more.
- Surveys show customers spend more when they use a NFC Contactless Mobile Payment solution.
- Less time needed at cashier: NFC speeds up the transaction workflow
 - Integration of couponing, loyalty & payment
- Less lost Sales because a mobile is always in the pocket (more then a wallet).
- Less fraud due to minimizing the fraud window.
- Less cash to handle at cashier

Roadblocks (?)

- Lack of commercially available SWP/NFC Handsets
- Unclear Business Models
- Lack of contactless PoS infrastructure
- Co-operation between ecosystem players

Some Key Road Blocks and Mitigation actions taken

■ **Lack of availability of SWP Handsets**

- GSMA developed ***SWP Device Requirements*** document to be used as a basis for MNO SWP handset procurement. V2 available at:
- Handset manufacturers are now engaged in SWP device development. Expect commercially available SWP NFC devices **this year**.

■ **Lack of clarity in roles and responsibilities in Trusted Service Management (TSM)**

- GSMA is working with European Payment Council (EPC) to define ***TSM Requirements document***
 - This will define the core set of business and technical requirements for TSM interfaces with (a) Banks; (b) MNOs.

■ **Roadmap for retailers to deploy contactless infrastructure is unclear**

- ***GSMA is engaging with Financial Industry*** to understand the roadmaps for deploying contactless infrastructure. Good progress in some parts of the world (Asia, Europe, USA).



4. Next Steps

Trends in Mobile NFC

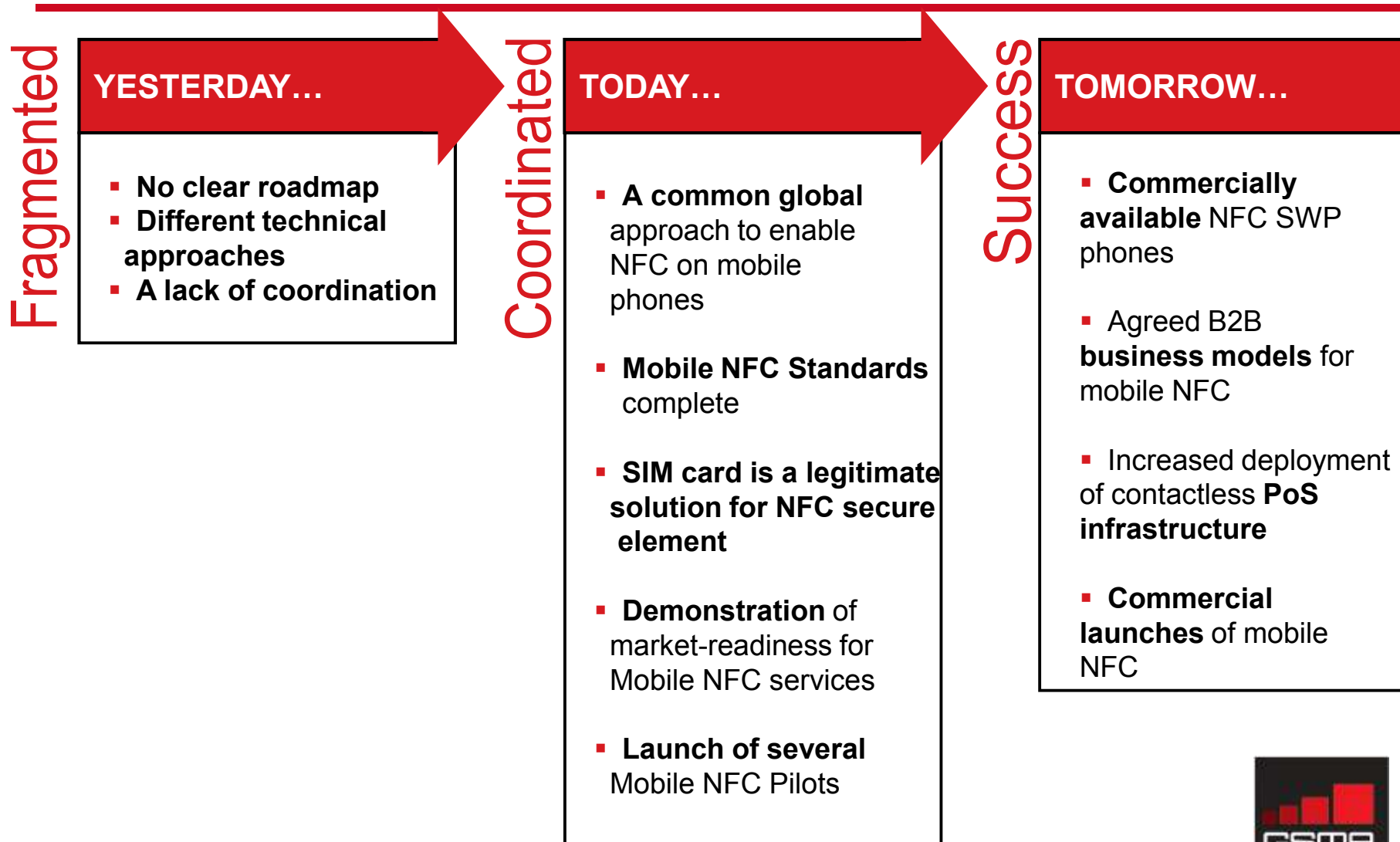

Keynote

- *Only by working **together** through Cross-Industry Collaboration can we make Mobile NFC M-Payment a **WIN-WIN** service for **ALL!***

Thank You!



References

- **Pay-Buy-Mobile Website** <http://www.gsmworld.com/pbm/index.shtml>

- **Pay-Buy-Mobile Business Opportunity Analysis Public White Paper**
 - See http://www.gsmworld.com/documents/pbm/gsma_pbm_wp.pdf

- **NFC Technical Guidelines V2 White Paper**
 - See http://www.gsmworld.com/documents/nfc/gsma_nfc2_wp.pdf

- **NFC Mobile NFC Services White Paper**
 - See http://www.gsmworld.com/news/press_2007/press07_22.shtml

- **GSMA Requirements for SWP NFC Handsets V2**
 - http://www.gsmworld.com/documents/reqs_sw_p_nfc_handsets_v2.pdf

- **Press Release 18 November Macau**
 - <http://www.gsmworld.com/newsroom/press-releases/2008/2090.htm>

